

The easiest way to use your own push-button: The TLT-MOTO CAN-SWITCHBOX

[24B] Left Hand Control Module
or
[22B-1] Right Hand Control Module

- 1 Red/Orange Battery Fuse
- 2 Black Ground
- 3 White/Red CAN_High
- 4 White/Black CAN_Low

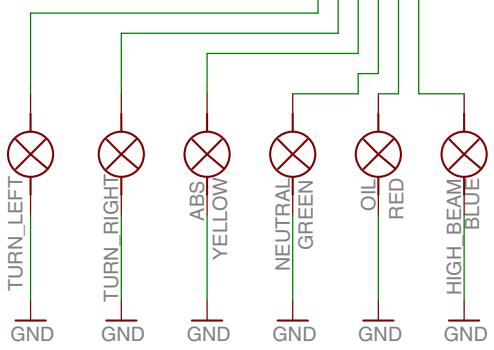
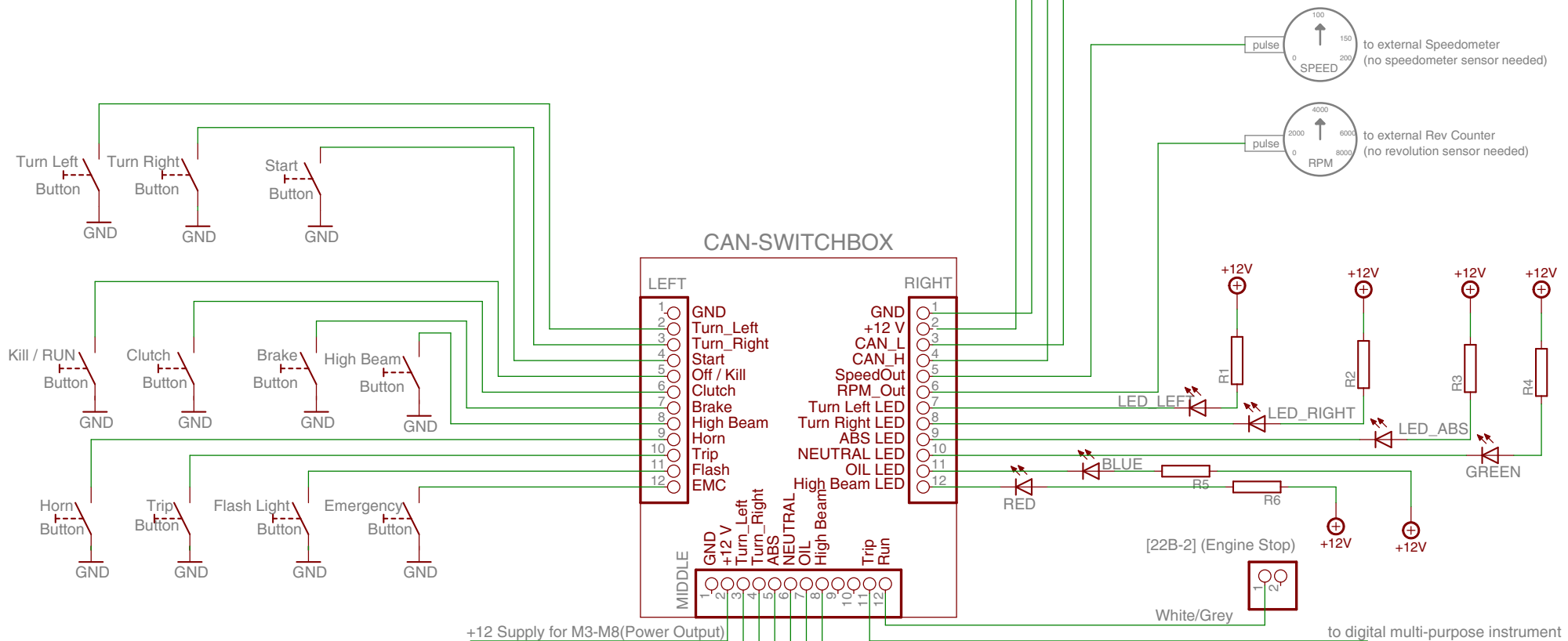

<h2>www.TLT-MOTO.DE</h2>	
TITLE: TLT-MOTO V6_1	
Document Number:	REV: 6.1
Date: 05.05.2022 10:18:46	Sheet: 1/1